



Honeywell

Sensing and Control

SWITCHES



ISO 9001
QS9000





SWITCH APPLICATIONS

The odds are that Honeywell Sensing and Control can meet your switch demands. Designers of heavy-duty equipment have trusted Honeywell pressure and vacuum switches for many years in applications that are constantly subjected to harsh environments...from chemical splashes, salt water, high pressure spikes...we've got you covered. Our standard line is quite extensive, but if it is not exactly what your requirements call for we can modify an existing part or create an original just for you. Honeywell has produced millions of custom-built switches for automotive, pool and spa, powershift transmissions, anti-skid braking systems, excavator hydraulic systems, water pump systems, and dental air compressors, to name just a few. Our highly skilled model shop, certified lab and engineering staff can work with you through the design phase, prototype stage, all the way through to the testing phase. And if time is a crucial factor, rapid prototyping technology can now allow us to provide you with a sample in days.



WARNING! Suitability of application is responsibility of user. Extreme heat and vibration should be avoided at mounting points such as on top of an engine over a hot manifold. (MAX operation temp 250° F). Always install by using a wrench on the hex base. Torquing at any other part of the switch voids the warranty or may cause malfunction. A Polyimide film diaphragm is utilized in the pressure switch and is not recommended for use with water. However, a Teflon diaphragm is available for water applications. Compatibility with the brass or steel external pressure switch material is the responsibility of the user. For maximum operating pressures see appropriate switch family specifications. Contact Honeywell Engineering whenever use of switch or fluid compatibility is questioned.

- Ultra Duty Pressure Switches 10-400 psi p.3
- Extended Duty Pressure Switches 0.5-150 psi p.4
- Extended Duty Vacuum Switches 1.1-22" Hg p.6
- Extended Duty Piston Switches 200-1000 psi. p.7
- Factory Set Variable Differential Pressure & Vacuum Switches 2-70 psi & 2-22" Hg p.8
- High Pressure Environmentally Sealed Extreme-Duty Switches 35-3000 psi p.9



WARNING PERSONAL INJURY

DO NOT USE these products as safety or emergency stop devices, or in any other application where failure of the product could result in personal injury. **Failure to comply with these instructions could result in death or serious injury.**



Set Points from 10-400 psi

5000 Series Ultra Duty Pressure Switch

Honeywell Sensing and Control has designed a high pressure/low set point pressure switch for applications that see sudden pressure spikes and high system pressures that can result in early switch failures. This series has been strengthened to prevent cracking of the base with plated steel and screw machined components in a 3-piece design. Modifications to the effective area of the pressure cavity and size of the diaphragm button and diaphragm o-ring are what makes the switch capable of handling sudden pressure transients and high system pressures that are common in applications such as braking, transmission and hydraulic systems.

The switch's physical appearance is similar to our 5000 Series switches with a height of only 2.3" (approx) and a diameter of 1.47". In comparison to our 5000 Series Switch the burst rating has significantly increased from 1250 psi to over 4000 psi on the new design.

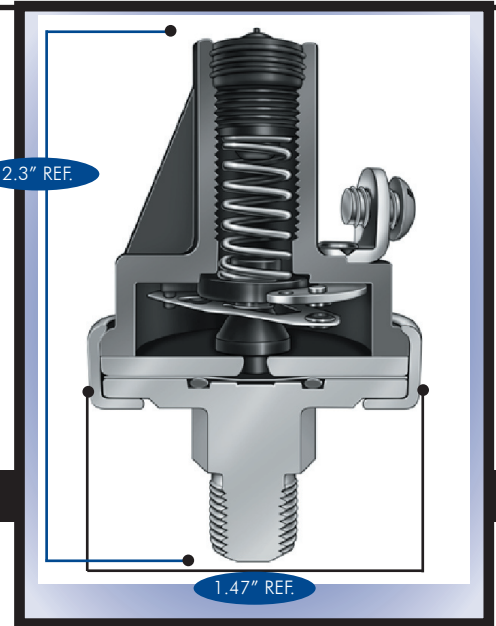

Specifications

Type: Direct action blade contact
 Contacts: Silver alloy, gold plated
 Set Point Range: 10-400 PSI
 Operating Pressure: 500 PSI
 Proof Pressure: 2000 PSI
 Burst Pressure: 4000 PSI
 Base: Plated Steel — Screw Machined
 3-piece construction
 Diaphragm: Polyimide Film
 Connector: 1/8-27 NPT Male Thread
 Temperature Range: -40°F to +250°F
 Terminals: #8-32 screws, 1/4" blade, 280 Series Metripack
 Circuitry: SPST-N.O., N.C., SPDT
 Cover: Glass Reinforced Polyester
 Options: Base connector sizes, wire leads, N.O./N.O. dual circuit and N.C./N.C. dual circuit.

Ratings:

Resistive: 15 AMP- 6 VDC
 8 AMP- 12 VDC
 4 AMP- 24 VDC
 Inductive: 1 AMP- 120 VAC
 0.5 AMP- 240 VAC

5000 Series Ultra Duty Pressure Switches			2 Terminals		Metri-Pack Integral Connector (See Note 1)			
Contact Setting	Factory Set At	Circuitry	Screw Part #	Blade Part #	Contact Setting	Factory Set At	Circuitry	Part #
10-35 PSI ± 4 psi	20 PSI	N.O.	83298	83313	10-30 PSI ± 4 psi	20 PSI	N.O.	83328
		N.C.	83299	83314			N.C.	83329
		DC*	83300	83315			DC*	83330
35-75 PSI ± 6 psi	60 PSI	N.O.	83301	83316	30-65 PSI ± 5 psi	45 PSI	N.O.	83331
		N.C.	83302	83317			N.C.	83332
		DC*	83303	83318			DC*	83333
75-150 PSI ± 10 psi	100 PSI	N.O.	83304	83319	65-125 PSI ± 7 psi	85 PSI	N.O.	83334
		N.C.	83305	83320			N.C.	83335
		DC*	83306	83321			DC*	83336
150-250 PSI ± 15 psi	200 PSI	N.O.	83307	83322	125-200 PSI ± 10 psi	165 PSI	N.O.	83337
		N.C.	83308	83323			N.C.	83338
		DC*	83309	83324			DC*	83339
250-400 PSI ± 20 psi	300 PSI	N.O.	83310	83325	200-400 PSI ± 15 psi	300 PSI	N.O.	83340
		N.C.	83311	83326			N.C.	83341
		DC*	83312	83327			DC*	83342

Approximate Dead Band Standard Switches

Contact Setting	Dead Band
10-35 PSI	15-25 PSI
35-75 PSI	25-35 PSI
75-150 PSI	40-60 PSI
150-250 PSI	50-70 PSI
250-400 PSI	80-100 PSI

Metri-Pack Switches

10-30 PSI	20-35 PSI
30-65 PSI	35-55 PSI
65-125 PSI	60-85 PSI
125-200 PSI	85-115 PSI
200-400 PSI	150-200 PSI

Note 1: Mating connector for N.O. and N.C. is Packard Part# 15300027; Mating connector for DC is Packard Part# 12034147.

DC*: The N.C. is the reference circuit for the DC Switch; the N.O. circuit is not adjusted. The approximate dead band between the N.C. and N.O. circuit is shown in the charts. For applications requiring the N.O. circuit as the reference circuit, the N.C. circuit is not adjusted.



Set Points from 0.5 to 150 psi

5000 Series Extended Duty Pressure Switch With Direct Action Blade Contacts

The 5000 Series switch is specifically designed to stand up to extended duty applications. This switch is factory set but capable of field adjustment. It features a Kapton diaphragm for compatibility with a wide variety of fluids, and various terminations including a Metri-Pack connector that forms a tight seal when connected. Among the outstanding design benefits are its durable construction, compact size, and enhanced set point integrity.

Standard Specifications

Type: Direct action blade contact
 Contacts: Silver alloy, gold plated
 Set Point: Factory set from 0.5 to 150 PSI
 Operating Pressure: 150 PSI for 0.5-24 PSI set point range, 250 PSI for 25-150 PSI set point range
 Pressure: 500 PSI
 Burst Pressure: 750 PSI for 0.5-24 PSI set point range, 1250 PSI for 25-150 PSI set point range.



Switch Roof P/N 79380 for Vacuum and Pressure

Ratings:

Resistive:	15 AMP-	6 VDC
	8 AMP-	12 VDC
	4 AMP-	24 VDC
Inductive:	1 AMP-	120 VAC
	0.5 AMP-	240 VAC

Diaphragm: Polyimide film

Temperature

Range: -40° F to + 250° F

Connector: 1/8 -27 NPT male thread

Terminals: #8-32 screws, 1/4" blade, 280 Series Metri-Pack

Circuitry: SPST-N.O., N.C., 1 circuit adjustable dual circuit, or 2 circuits adjustable dual circuit.

Also available are N.O./N.O. dual circuit and N.C./N.C. dual circuit.

Base: Plated Steel

Cover: Glass reinforced polyester

Options: Brass, plastic or stainless steel base; various base connector thread sizes; wire leads (potted & sealed).

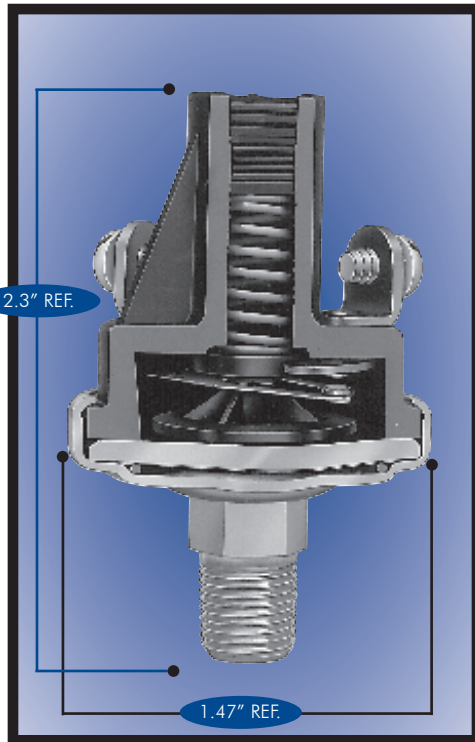

5000 Series Switch with Screw Terminals

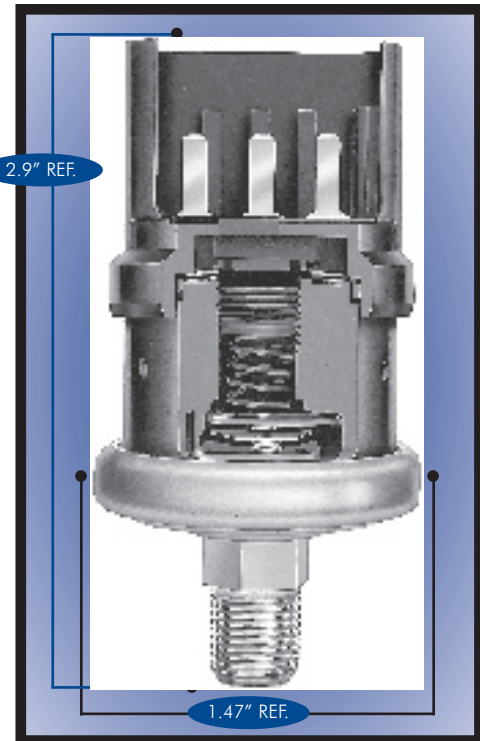

5000 Series Switch with Metri-Pack Terminal

NOTE: OPERATING MEDIA (PRESSURE SWITCH)

The pressure switch is designed to operate with air, motor oils, transmission oils, jet fuels and other similar hydrocarbon media.



5000 Series Pressure Switch With Standard Terminal

			Single Circuit 1 Terminal		Single Circuit 2 Terminals		Dual Circuit One circuit adjustable ¹		Dual Circuit Both circuits adjustable ²		
Contact Setting	Factory Set At	Circuitry	Part Number		Part Number		Part Number		Contact Setting ³	Part Number	
			Screw	Blade	Screw	Blade	Screw	Blade		Screw	Blade
0.5-1 PSI ±0.3	1 PSI	N.O.	78630	78631	78628	78629	78711	78712	3-4 PSI ±0.5	76081	76086
		N.C.	78634	78635	78632	78633					
1.1-3 PSI ±0.5	2 PSI	N.O.	78142	78399	76051	76056	76071	76076	5-8 PSI ±1	76582	76590
		N.C.	78149	78406	76061	76066					
3.1-7 PSI ±1	4 PSI	N.O.	78143	78400	76575	76583	76579	76587	9-24 PSI ±2	76082	76087
		N.C.	78150	78407	76577	76585					
8-13 PSI ±2	10 PSI	N.O.	78144	78401	76576	76584	76580	76588	25-50 PSI ±3	76083	76088
		N.C.	78151	78408	76578	76586					
14-24 PSI ±3	15 PSI	N.O.	78145	78402	76052	76057	76072	76077	51-90 PSI +5/-2	76084	76089
		N.C.	78152	78409	76062	76067					
25-50 PSI ±5	35 PSI	N.O.	78146	78403	76053	76058	76073	76078	91-150 PSI +8/-2	76085	76090
		N.C.	78153	78410	76063	76068					
51-90 PSI ±7	60 PSI	N.O.	78147	78404	76054	76059	76074	76079			
		N.C.	78154	78411	76064	76069					
91-150 PSI ±10	100 PSI	N.O.	78148	78405	76055	76060	76075	76080			
		N.C.	78155	78412	76065	76070					

5000 Series Pressure Switch With Metri-Pack Terminal

			Single Circuit (Mates with Packard P/N 15300027)		Dual Circuit One circuit adjustable ¹ (Mates with Packard P/N 12034147)		Dual Circuit Both circuits adjustable ² (Mates with Packard P/N 12034147)	
Contact Setting	Factory Set At	Circuitry	Part Number	Part Number	Contact Setting ³	Part Number		
1-3 PSI ±0.5	2 PSI	N.O.	77029	77038	3-4 PSI ±0.5	77047		
		N.C.	77020					
4-6 PSI ±1	5 PSI	N.O.	77030	77039	5-10 PSI ±1	77048		
		N.C.	77021					
7-12 PSI ±2	10 PSI	N.O.	77031	77040	11-24 PSI ±2	77049		
		N.C.	77022					
13-24 PSI ±3	20 PSI	N.O.	77032	77041	25-46 PSI ±3	77050		
		N.C.	77023					
25-46 PSI ±5	35 PSI	N.O.	77033	77042	47-76 PSI +5/-2	77051		
		N.C.	77024					
47-76 PSI ±6	60 PSI	N.O.	77034	77043	77-100 PSI +7/-2	77052		
		N.C.	77025					
77-100 PSI ±7	85 PSI	N.O.	77035	77044	101-126 PSI +9/-2	77053		
		N.C.	77026					
101-126 ±9	115 PSI	N.O.	77036	77045	127-150 PSI +10/-2	77054		
		N.C.	77027					
127-150 PSI ±10	135 PSI	N.O.	77037	77046				
		N.C.	77028					

Notes:

- The N.C. circuit is the reference circuit for the dual circuit switch; the normally open circuit is not adjusted. The expected dead band between the N.C. & N.O. circuit is shown in the chart below. For applications requiring the normally open circuit as the reference circuit the N.C. circuit is not adjusted.
- Switch may be adjusted so that:
 - N.C. circuit opens before N.O. circuit closes.
 - N.C. and N.O. circuit have same set point.
 - N.O. circuit closes before the N.C. circuit opens. (There is no dead band and both circuits are on for a brief period of time.)
- The tolerances given in the table are applicable to a switch adjusted so that the N.O. circuit closes before the N.C. circuit opens and applies to the N.C. circuit. The N.O. set point and tolerances are such that a minimum overlap of 1 PSI exists during which both circuits are on.

Note 1: Expected Dead Band (Higher than N.C. circuit)

Contact Setting	Dead Band
0.5-3 PSI	1.5 PSI
4-7 PSI	2.5 PSI
8-13 PSI	3.5 PSI
14-24 PSI	8 PSI
25-50 PSI	15 PSI
51-90 PSI	23 PSI
91-150 PSI	40 PSI

Set Points from 1.1" to 22" Hg

5000 Series Extended Duty Vacuum Switches With Direct Action Blade Contacts

The 5000 Series switch is specifically designed to stand up to extended duty applications. This switch is factory set. It features a fluorosilicone rubber diaphragm for compatibility with a wide variety of fluids, and various terminations including a Metri-Pack connector that forms a tight seal when connected. Among the outstanding design benefits are its durable construction, compact size, and enhanced set point integrity.

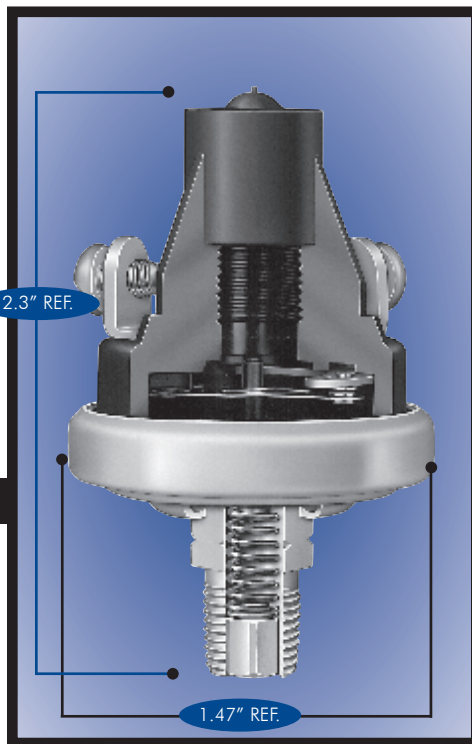

5000 Series Switch with Screw Terminals



Switch Boot P/N 79380 for Vacuum and Pressure

Standard Specifications

Type: Direct action blade contact
 Contacts: Silver alloy, gold plated
 Set Point: Factory set
 Vacuum: 1.1 to 22" Hg
 Operating Pressure: 30" Hg vacuum max.
 Burst Pressure: 150 PSI

Ratings:

Resistive: 15 AMP- 6 VDC
 8 AMP- 12 VDC
 4 AMP- 24 VDC
 Inductive: 1 AMP- 120 VAC
 0.5 AMP- 240 VAC
 Diaphragm: Fluorosilicone elastomer
 Temperature Range: -40° F to + 250° F
 Connector: 1/8-27 NPT male thread
 Terminals: #8-32 screws, 1/4" blade, 280 Series Metri-Pack
 Circuitry: SPST-N.O., N.C.
 Base: Brass
 Cover: Glass reinforced polyester
 Options: Various base connector thread sizes; wire leads (potted & sealed).

5000 Series Vacuum Switch

Contact Setting	Circuitry	Internally Grounded		Two Terminals	
		Part Number		Part Number	
		Screw	Blade	Screw	Blade
1.1-22" Hg	N.O.	78813	78814	77342	77344
	N.C.	78815	78816	77343	77345

Standard set points are 2"Hg(27" H₂O), 4"Hg, 9"Hg, and 17"Hg

Contact Setting	Tolerance
1.1-3"Hg (15-41"H ₂ O)	±.22"Hg(3"H ₂ O)
4-8"Hg	±1"Hg
9-17"Hg	±2"Hg
18-22"Hg	±3"Hg

Set Points from 200 to 1000 psi

5000 Series Extended Duty Piston Switches With Direct Action Blade Contacts

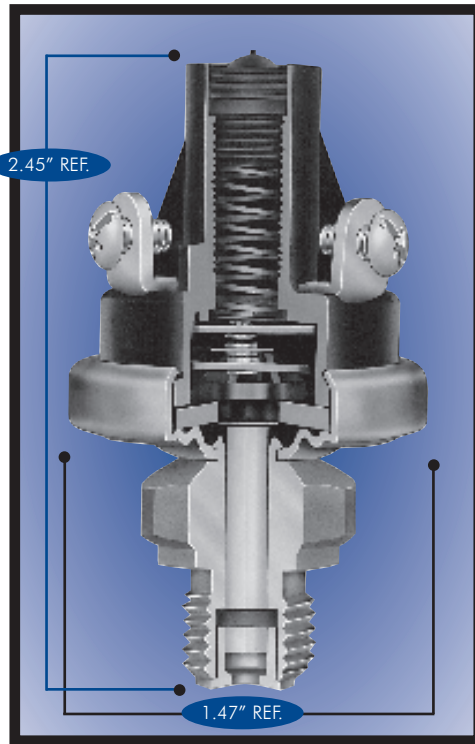

5000 Series Piston Switch with Screw Terminals

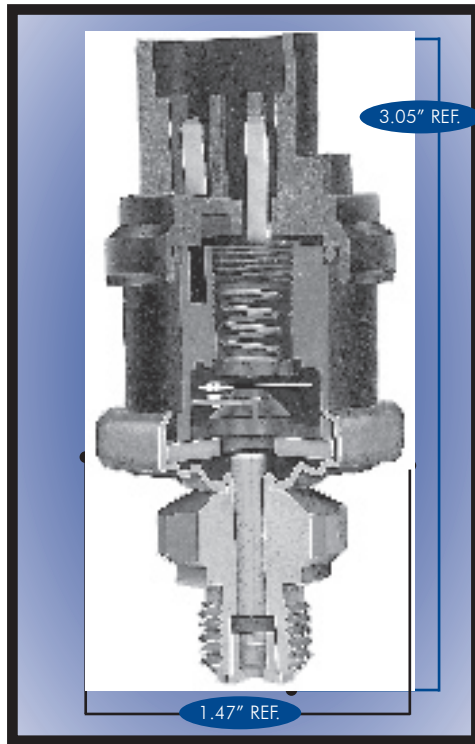

5000 Series Piston Switch with Metri-Pack Terminal

The 5000 Series piston switch is specifically designed for extended duty applications with set point requirements from 200 to 1000 PSI. This switch is factory set with various terminations available including a Metri-Pack connector that forms a tight seal when connected. Among the outstanding design benefits are its durable construction, compact size, and enhanced set point integrity. This switch has a wide media compatibility making it ideal for a number of applications.

Standard Specifications

Type:	Direct action blade contact
Contacts:	Silver alloy, gold plated
Set Point:	Factory set
Pressure:	200-1000 PSI
Operating Pressure:	1000 PSI
Proof Pressure:	2000 PSI
Burst Pressure:	3000 PSI

Ratings:

Resistive:	15 AMP-	6 VDC
	8 AMP-	12 VDC
	4 AMP-	24 VDC
Inductive:	1 AMP-	120 VAC
	0.5 AMP-	240 VAC
Standard Seal:	Nitrile (others available)	
Temperature Range:	-40° F to + 250° F	
Connector:	1/2-20 UNF (o-ring fitting)	
Terminals:	#8-32 screws, 1/4" blade, 280 Series Metri-Pack	
Circuitry:	SPST-N.O., N.C., D.C.	
Base:	Steel	
Cover:	Glass reinforced polyester	
Options:	Brass, stainless steel base; o-ring fittings; seal for brake fluid; wire leads (potted and sealed); boot p/n 79380 (see photo on page 4.)	

Piston Switch with Standard Terminal			Single Circuit		Dual Circuit * one circuit adjustable	
Contact Setting Range	Approximate Differential	Circuitry	Part Number		Part Number	
			Screw	Blade	Screw	Blade
200-400 ±30	30-100	N.O.	79700	79701	79712	79713
		N.C.	79702	79703		
401-800 ±60	40-125	N.O.	79704	79705	79714	79715
		N.C.	79706	79707		
801-1000 ±90	50-180	N.O.	79708	79709	79716	79717
		N.C.	79710	79711		

Piston Switch with Metri-Pack Terminal			Single Circuit (Mates with Packard P/N 15300027)	Dual Circuit * one circuit adjustable (Mates with Packard P/N 12034147)
Contact Setting Range	Approximate Differential	Circuitry	Part Number	
			Part Number	Part Number
200-350 ±30	30-100	N.O.	79718	79724
		N.C.	79719	
351-500 ±45	40-125	N.O.	79720	79725
		N.C.	79721	
501-750 ±60	50-150	N.O.	79722	79726
		N.C.	79723	

* Note: The N.C. circuit is the reference circuit for the dual circuit switch; the normally open circuit is not adjusted. For applications requiring the normally open circuit as the reference circuit, the N.C. circuit is not adjusted.
Specify: 1. Set point 2. Actuate on increasing or decreasing pressure 3. SPST N.O. or N.C. SPDT.

Set Points from 2 to 70 psi and 2" to 22" Hg

Series III Factory Set Variable Differential Pressure & Vacuum Switches With Snap Action Contacts

The Series III switch is a customizable switch built per customer specifications. It features a non-ferrous chamber and excellent set point integrity at extreme temperatures. The exclusive snap switch features: Low-contact resistance, wiping action, fast transfer time, gold over silver contacts, and an adjustable differential. It's been thoroughly tested for shock and vibration resistance and is particularly valuable in applications where hysteresis, fast transfer time, and low contact resistance are vital.

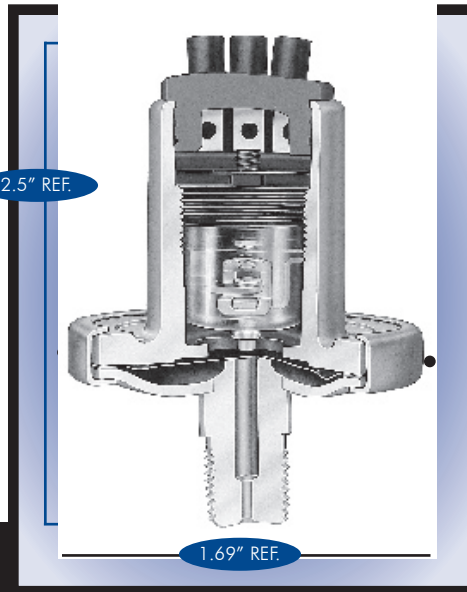

Series III Pressure Switch

(Vacuum Switch Similar)

Series III pressure and vacuum switches are custom built switches designed to customer specifications therefore minimum ship quantities are required and are not available off-the-shelf.

Vacuum Switch Standard Specifications

Type: Snap action switch
 Set Point: Factory set
 Vacuum: 2 to 22" Hg
 15 to 36" H₂O
 Operating Pressure: 200 PSI
 Proof Pressure: 350 PSI
 Burst Pressure: 500 PSI

Ratings:

Resistive: 15 AMP- 6 VDC
 8 AMP- 12 VDC
 4 AMP- 24 VDC
 Inductive: 1 AMP- 120 VAC
 0.5 AMP- 240 VAC
 Dry circuits

Diaphragm: Silicone rubber
 Temperature Range: -40° F to + 250° F
 Connector: 1/8 -27 PTF SAE short male thread
 Terminals: 8" Wire leads-18 ga.
 Circuitry: SPST-N.O. or N.C., SPDT
 Base: Brass
 Housing: Die cast zinc
 Options: Silver contacts, silver soldered base, fluorosilicone rubber diaphragm
 Terminations: Wire leads with wide selection of Cannon, Packard, AMP, and others available
 Connectors: 1/4" and 3/8" PTF SAE short; 1/2-20 UNF (o-ring fitting); 3/8-24 UNF (3/16" tube); 7/16-24 UNF (1/4" tube); and Metric

Pressure Switch Standard Specifications

Type: Snap action switch
 Set Point: Factory set
 Pressure: 1-70 PSI
 Operating Pressure: 200 PSI
 Proof Pressure: 350 PSI
 Burst Pressure: 500 PSI

Ratings:

Resistive: 15 AMP- 6 VDC
 8 AMP- 12 VDC
 4 AMP- 24 VDC
 Inductive: 1 AMP- 120 VAC
 0.5 AMP- 240 VAC
 Dry circuits

Diaphragm: Beryllium copper
 Temperature Range: -40° F to + 250° F
 Connector: 1/8 -27 PTF SAE short male thread
 Terminals: 8" Wire leads-18 ga.
 Circuitry: SPST-N.O. or N.C., SPDT
 Base: Brass
 Housing: Die cast zinc
 Options: Silver contacts, silver soldered base
 Terminations: Wire leads with wide selection of Cannon, Packard, AMP, and others available
 Connectors: 1/4" and 3/8" PTF SAE short; 1/2-20 UNF (o-ring fitting); 3/8-24 UNF (3/16" tube); 7/16-24 UNF (1/4" tube); and metric

Pressure Switch/Factory Set

Reference #	Set Point Range	Differential
120000	2-4 PSI	1-1.5 PSI
120001	4-12 PSI	2-6 PSI
120002	12-24 PSI	8-12 PSI
120003	24-40 PSI	10-18 PSI
120004	40-70 PSI	15-20 PSI

Vacuum Switch/Factory Set

Reference #	Set Point Range	Differential
120005	15-36" H ₂ O	4-12" H ₂ O
120006	2-6" Hg	0.4-1" Hg
120007	6-12" Hg	0.4-1" Hg
120008	12-22" Hg	0.6-1.5" Hg

Specify: 1. Set Point
 2. Actuate on increasing or decreasing pressure
 3. SPST N.O. or N.C., SPDT

Set Points from 35 to 3000 psi

Series V High Pressure Environmentally Sealed, Extreme-Duty Switches With Snap Action Contacts

The Series V switch is a high pressure switch with set points up to 3000 PSI and is built to exact customer specifications. Excellent set point integrity at extreme temperatures and wide fluid compatibility make this switch ideal for extreme duty applications. And, under all operating conditions, it boasts an excellent response time. Like the Series III, the Series V exclusive snap switch has an adjustable differential, low contact resistance, wiping action, fast transfer time, and gold over silver contacts. This switch is beneficial where hysteresis, fast transfer time, and low contact resistance are vital.

Standard Specifications

Type: Snap action switch
 Set Point: Factory set
 Pressure: 35-300 PSI (elastomeric diaphragm)
 100-3000 PSI (steel piston)

Operating Pressure: Diaphragm 300 PSI
 Piston 3000 PSI
 Proof: Diaphragm 500 PSI
 Piston 5000 PSI
 Burst: Diaphragm 2000 PSI
 Piston 10000 PSI

Ratings:

Resistive: 15 AMP- 6 VDC
 8 AMP- 12 VDC
 4 AMP- 24 VDC
 Inductive: 1 AMP- 120 VAC
 0.5 AMP- 240 VAC
 Dry circuits

Temperature Range: -40°F to +250°F
 Connector: Diaphragm 1/8-27 PTF
 SAE short male thread
 Piston: 3/4-16 UNF (o-ring fitting)
 Terminals: 8" Wire leads-18 ga.
 Circuitry: SPST-N.O. or N.C., SPDT
 Base: Plated steel
 Housing: Plated steel
 Options: Silver contacts
 Terminations: Wide selection of
 Cannon, Packard, AMP,
 and others available
 Connectors: 1/2-20 UNF (o-ring fitting);
 9/16-18 UNF (o-ring fitting);
 M14x1.5 (o-ring fitting);
 Others available upon request.

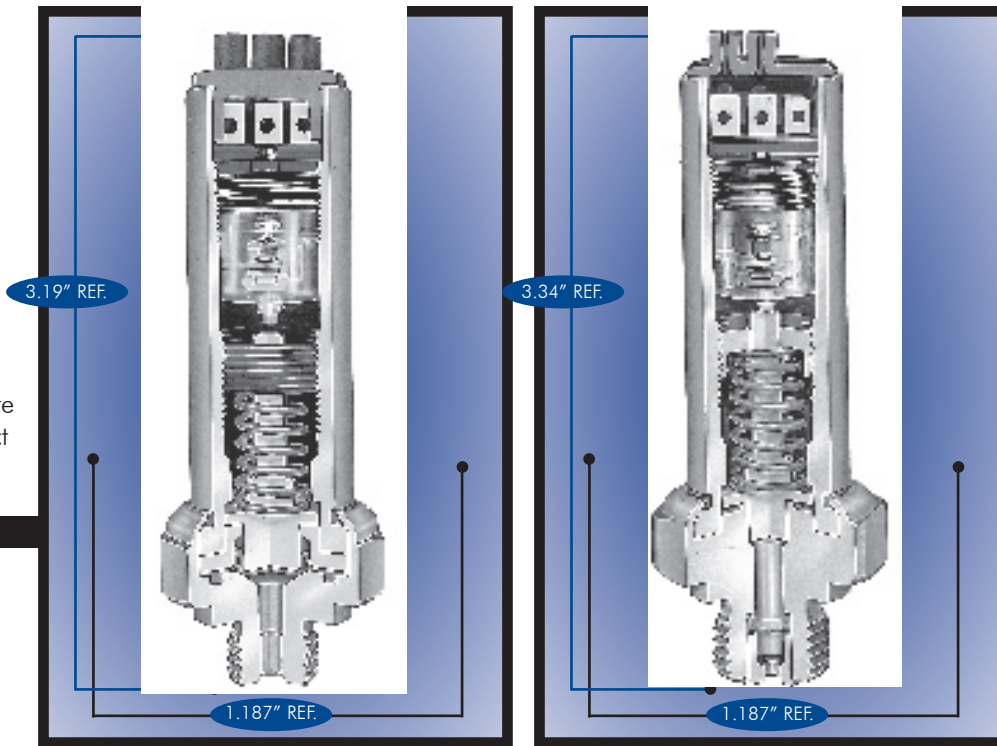

Diaphragm Type

Piston Type

Diaphragm Type

Reference Number	Set Point Range	Differential
26900	35-50 PSI	10-15 PSI
26901	50-100 PSI	10-15 PSI
26902	100-200 PSI	10-15 PSI
26903	200-300 PSI	10-20 PSI

Piston Type

Reference Number	Set Point Range	Differential
26904	100-150 PSI	35-50 PSI
26905	150-250 PSI	50-75 PSI
26906	250-500 PSI	75-100 PSI
26907	500-750 PSI	100-150 PSI
26908	750-1000 PSI	150-300 PSI
26909	1000-1250 PSI	175-350 PSI
26910	1250-1500 PSI	175-360 PSI
26911	1500-1750 PSI	220-370 PSI
26912	1750-2000 PSI	230-380 PSI
26913	2000-2250 PSI	250-390 PSI
26914	2250-2500 PSI	355-400 PSI
26915	2500-2750 PSI	370-420 PSI
26916	2750-3000 PSI	385-450 PSI

- Specify:**
1. Set Point
 2. Actuate on increasing or decreasing pressure
 3. SPST N.O. or N.C., SPDT

Series V pressure and vacuum switches are custom built switches designed to customer specifications therefore minimum ship quantities are required and are not available off-the-shelf.



Switch Definitions and Terminology

Pressure/Vacuum Switch - A device that senses a change in pressure/vacuum and opens or closes an electrical circuit when the set point is reached.

Set Point - The pre-determined pressure/vacuum value that is required to open or close the electrical contacts in the switch.

Electrical Contacts - The elements in the switch that electrically respond to the media applied to the actuator. Snap action contacts with a "self-cleaning" wiping effect are used in Series III and Series V switches. Direct action blade contacts are used in the 5000 Series.

Pressure Switch Actuator - The member in the switch which receives the media and ultimately strokes the electrical contacts to open or close at the designated set point. The actuator in the Series III is a beryllium copper or silicone rubber diaphragm. An elastomeric diaphragm or piston actuator is used in the Series V. The 5000 Series uses a polyimide film diaphragm.

Normally Open (SPST-N.O.) - A normally open switch does not conduct an electrical signal until the actuator is moved by the media causing the contacts to close.

Normally Closed (SPST-N.C.) - A normally closed switch conducts electricity until the actuator is moved by the media causing the contacts to open.

Dual Circuit (SPDT) - A normally open and normally closed circuit are contained in a switch.

Dual Circuit (N.O./N.O.) - Switch contains two normally open circuits.

Dual Circuit (N.C./N.C.) - Switch contains two normally closed circuits.

System Pressure/Vacuum - This is the normal pressure/vacuum that would be

present at the switch actuator. This value is important in order to apply the proper switch configuration. Even though the set point may be relatively low, the system pressure would continue to be applied to the switch actuator in most cases.

Proof Pressure - This specification is the maximum over-pressure condition that the switch can have for a specified period of time and still maintain set point integrity.

Burst Pressure - This specification is the maximum over pressure condition that the switch can withstand without experiencing leakage.

Dry Circuit Load - Typically this would be a very low electrical load associated with microprocessors when the open circuit voltage is .03V or less and the current is 40mA or less.

Resistive Load - A load in which the voltage is in phase with the current.

Inductive Load - A load in which the voltage leads the current.

Motor Load - The load of a motor at rated horsepower and speed.

Capacitive Load - A load which the current leads the voltage.

Differential - The difference between opening (actuation) pressure and the closing (de-actuation) set points. This is also referred to as "dead band". For example, a switch set at 150 PSI to open on increasing pressure and close at 95 PSI on decreasing pressure would have a differential of 55 PSI (150-95=55).

Conversion Factors		
Convert	To	Multiply By
kPa	PSI	.145
PSI	kPa	6.8948
BARS	PSI	14.5
PSI	BARS	.069
Hg"	PSI	.4912
PSI	Hg"	2.036
H ₂ O"	PSI	.03613
PSI	H ₂ O"	27.6778
H ₂ O"	Hg"	.07355
Hg"	H ₂ O"	13.5962
C°	F°	1.8(C° + 17.78)
F°	C°	F-32÷1.8





Honeywell's Springfield and Spring Valley, Illinois facilities manufacture a broad range of electro and electronic-mechanical products that include Hobbs hour meters, pressure and vacuum switches, off-highway vehicular lighting, transmission shifters, turn signal controls, rotary switches, and off-highway vehicular hand controls. Honeywell's customer base is very broad including industries such as automotive, agricultural, material handling, construction, marine, medical, heavy truck, lawn and garden, recreational, generators, compressors and aviation. Our commitment to continuous improvement and total quality management will allow for further expansion of its product lines and customer base while maintaining the highest standards of excellence.

MANUFACTURING

Honeywell's commitment to the customer in past years and present is what has helped us develop our world-class manufacturing systems. Some of the methods by which we continuously improve products and processes are as follows:

- Six Sigma methodology is a strategy used to accelerate improvements in our processes, products and services, and to reduce manufacturing costs and improve quality. It achieves this by relentlessly focusing on eliminating waste and reducing defects and variations.
- Continuous Flow Process utilizing "Rabbit Chase" concepts are used in the focused factories in order to achieve the lowest total cost, defect-free product.
- Single Minute Exchange of Dies (SMED method) provides reduced time in the molding cell.
- Statistical Process Control is used for measuring critical dimensions and controlling manufacturing processes.
- Poka-Yoke method and computerized test equipment are utilized to eliminate scrap and rework.
- Kanban cards are used to pull raw material and piece parts through the factory.
- Bar coding and electronic data interchange (EDI) are available.

QUALITY SYSTEMS

It is the goal of Honeywell to meet customer value-needs through continuously improved products and processes. That is the basis by which we work to create a partnership with our customers. Evidence of our commitment is proven by a goal of a Shipped Product Quality Level (SPQL) of 100 ppm. We utilize Advanced Quality Planning, and a QS9000 based quality system.





Warranty/Remedy

Honeywell warrants goods of its manufacture as being free of defective material and faulty workmanship. Contact your local sales office for warranty information. If warranted goods are returned to Honeywell during that period of coverage, Honeywell will repair or replace without charge those items it finds defective. **The foregoing is Buyer's sole remedy and is in lieu of all other warranties, expressed or implied, including those of merchantability and fitness for a particular purpose.**

While we provide application assistance, personally, through our literature and the Honeywell web site, it is up to the customer to determine the suitability of the product in the application.

Specifications may change at any time without notice. The information we supply is believed to be accurate and reliable as of this printing. However, we assume no responsibility for its use.

Sales and Service

Honeywell serves its customers through a worldwide network of sales offices and distributors. For application assistance, current specifications, pricing or name of the nearest Authorized Distributor, contact your local sales office or:

INTERNET: www.honeywell.com/hobbs

E-mail: honeywellhobbs.marketing@honeywell.com

For Honeywell pressure and vacuum switches contact the Springfield location at 217-753-7798 or visit www.honeywell.com/hobbs

Honeywell

Sensing and Control

Honeywell

P.O. Box 19424

Springfield, IL 62794-9424

USA

email: www.honeywellhobbs.marketing@honeywell.com

www.honeywell.com/hobbs

Catalog 10-1003, GLO Printed in the U.S.A.

© 2004 Honeywell International Inc. All Rights Reserved.

