

Hobbs Corporation

www.hobbs-corp.com

CONTROLS



 **Invensys**
An Invensys company

ISO 9001
QS9000



Hobbs Corporation

- Custom Controls and Switchesp.3
- F-N-R Shiftersp.4-5
- Multi-Purpose Turn Signal Switchesp.6-7
- Electronic Shifters.....p.8
- Proportional Retardersp.8



WARNING:

It is our customer's responsibility to determine the suitability of any Hobbs control in the customer's specific operating system. These controls are electrical mechanical and electronic devices which have a finite life. Only the customer can insure that appropriate system design, installation, guarding and/or fail-safe devices will protect users' safety and comply with applicable federal, state, local and industry safety and health regulations, codes and standards.

Due to the unlimited variety of machines, vehicles, equipment and system designs in which our controls may be used, it is impossible for Hobbs to provide advice regarding the suitability of a given control for a specific application. The flexibility of our products allows us to offer both standard and custom configurations. We can advise of the attributes of our products and our customers can examine our test results and failure mode analysis and obtain test models to see what meets the customer's needs. But ultimately, our customers' engineering departments must be the qualified experts in their own product field. If our product will be used in a safety critical application, the customer must undertake appropriate testing, evaluation and fail safe measures to prevent injury to the ultimate user.

Should you have any questions or if any of the above warning is unclear, please contact Hobbs Corporation Marketing Department at phone number 217-753-7752.

www.hobbs-corp.com



Custom Controls and Switches

Competition between off-road equipment manufacturers can be fierce. Let Hobbs help you distinguish yourself from the competition by working with you in developing your custom controls and switches.



We have innovative and flexible design capabilities coupled with cost-effective prices. Quick response including design, and "fit-up" prototypes in weeks versus months from your initial request provides the edge you need to shine over your competition. Control interfaces that are functional, rugged and aesthetically pleasing are an important part of the design process. The ability to ergonomically design numerous functions into one product is our strength.



Hobbs Technological and Process Capabilities used in Custom Controls and Switches:

- Pro/ENGINEER Software
- SolidWorks Software
- Stratasys Fused Deposition Modeling Machine (Rapid Prototyping)
- Programmable controllers
- Mold Flow Analysis



Control and Switch Capability:

- Sliding, toggle and button engagement
- Environmentally protected
- Night visibility/lighted components
- Directional
- Speed control
- Molded terminal arrays
- Ergonomically sensitive
- Indicator light panels

Equipment Applications:

- Snowmobiles
- Motorcycles
- Construction
- Material Handling
- All-Terrain Vehicles
- Forestry
- Agriculture
- Lawn & Garden



F-N-R Shifters

Hobbs shifters are designed for off-highway applications requiring direction and speed control. Our electro-mechanical shifters are built to withstand the harsh environments of the off-highway industry.

Most importantly, if you do not see an existing shifter to meet your equipment design specifications, we can work with you to design a custom fit.

F-N-R Shifter
Standard Dimensions

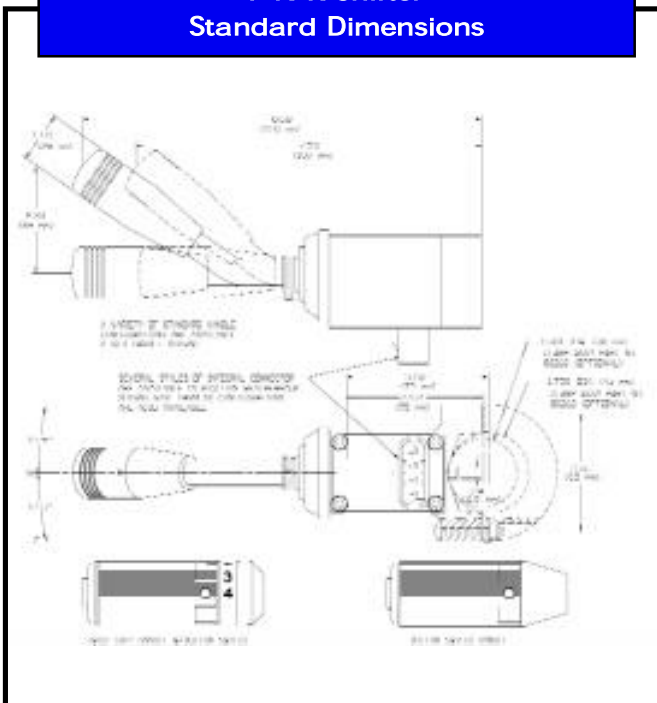

Specifications:

(Number of cycles based on testing at 12V)

<i>Cycle Life:</i>	(Rotary)	1,000,000
	(Shifter Handle)	500,000

Lever:

With drop-down neutral lock:	3,000,000
Without drop-down neutral lock:	5,000,000

Ratings:

<i>Operating Temperature Range:</i>	-40°C to + 85°C -40°F to +185°F (0 to 95% relative humidity)
-------------------------------------	--

<i>Operating Voltage Range:</i>	3V to 32V
---------------------------------	-----------

<i>Handle Dead Weight Limit:</i>	160 lbs. (712 newtons)
----------------------------------	---------------------------

<i>Solenoid Load:</i>	2.0 Amp at 12.8V with arc suppression
-----------------------	--

Features:

- Completely sealed
- Large sliding contacts
- Adaptable to 38mm, 45mm or 55mm mounting column
- Rugged
- Flexible design capability
- Up to 6 speeds with option bump feature
- Firm handle grip
- Variety of connectors
- Variety of button options

Shifters have been tested per the following specifications:

- Shock
- Vibration
- Mechanical
- Electrical
- Environmental
- Durability
- Performance



Forward-Neutral-Reverse Shifter

Part Number	80438	80909	80910	81248	81426	81521	81758	84105	84467	85874	86835	Custom
Mounting	Left	●	●	●	●	●	●	●	●	●	●	●
	Right	●				●				●	●	●
Neutral Column Size	38mm	●	●		●	●	●	●	●	●	●	●
	45mm	●	●		●	●	●	●	●	●	●	●
	55mm											
Lock	None			●		●	●					
	Drop Down	●	●	●	●	●		●	●	●	●	●
Speeds	2											●
	3				●		●					
	4			●				●				
	6									●		
	Bump							●				
	Buttons	Horn		●								
	Other				●							
Connectors	Wiper/Wash											●
	Integral Packard	●				●						
	Integral Deutsch			●	●	●		●	●	●		
	Wire Harness		●					●			●	

Contact Hobbs for options not listed.

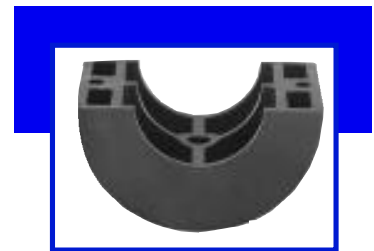

Mounting clamp for shifters available with or without locating pin for 1.5 inch (38mm.) or 1.75 inch (45mm.) or (55mm.) steering column. Clamps can be ordered separately.

Applications:

- Backhoes
- Front Loaders
- Telehandlers
- Forklifts
- Manlifts

www.hobbs-corp.com



Multi-Purpose Turn Signal Switches

Hobbs turn signal switches are built to complement the shifter or can also be mounted as stand alone. A variety of operations are available such as wiper speeds, head lamp control, button and auto cancel options. These switches can be tailored to meet your design requirements.

Specifications:

(Based on testing at 12V)

Minimum Cycle Life:

Turn Signal	8 Amps	100,000
Wiper	2 Amps	50,000
Washer	2 Amps	20,000
Head Lamp Dimmer	15 Amps	20,000

Ratings:

Operating Temperature Range: -40°C to + 85°C
 -40°F to +185°F
 (0 to 95% relative humidity)

Operating Voltage Range: 3V to 32V

Handle Dead Weight Limit: 160 lbs.
 (712 newtons)

Solenoid Load: 2.0 Amp
 with arc suppression

Turn Signal Standard Dimensions

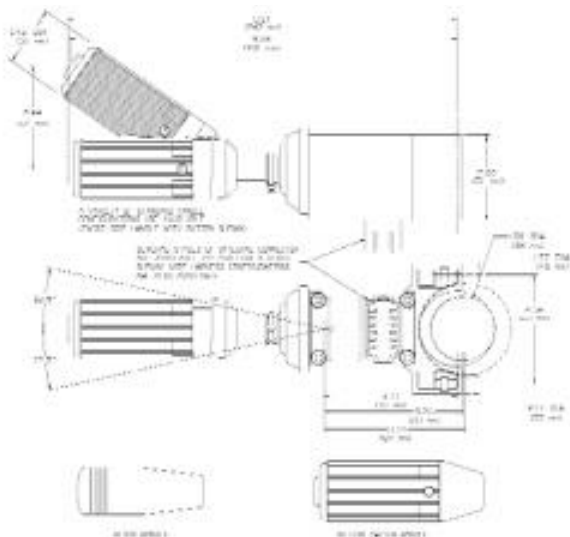

Features:

- Adaptable to 38mm, 45mm or 55mm columns
- Customized buttons
- Twist grip handle
- Auto cancel option
- Variety of connectors

Turn Signals have been tested per the following specifications:

- Shock
- Vibration
- Mechanical
- Electrical
- Environmental
- Durability
- Performance

Turn Signal Switches

	Part Number	79809	80279	80350	80876	80877	81601	81705	82570	84884	86320	86508	Custom
Column Size	38mm			●							●		
	45mm	●	●	●			●	●	●	●	●	●	
	55mm				●	●							
Wiper Speeds	1 Speed				●		●						
	Hi/Lo		●	●					●		●	●	
	Intermittent		●						●		●		
Lights	Turn Signal	●	●	●	●	●	●	●	●	●	●	●	
	Head Lamp Switch	●					●						
	Head Lamp Dimmer		●				●	●	●		●	●	
	Flash to Pass		●				●					●	
Auto Connectors	Hazard Warning									●	●		
	Wash		●	●	●		●		●		●	●	
	Horn							●			●	●	
	Integral Packard									●			
Cancel	Integral Deutsch			●	●	●	●	●					
	Wire Harness	●	●						●		●	●	
	Yes										●		
	No	●	●	●	●	●	●	●	●		●	●	

Contact Hobbs for options not listed.

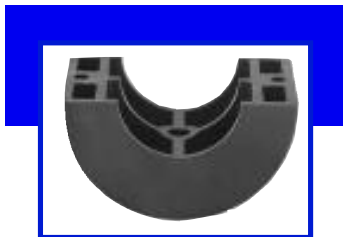

Mounting clamp for shifters available with or without locating pin for 1.5 inch (38mm.) or 1.75 inch (45mm.) or (55mm.) steering column. Clamps can be ordered separately.

Applications:

- On-Highway
- Truck
- Motor Coach



www.hobbs-corp.com



Electronic Shifters

The electronic shifter from Hobbs builds on the same rugged, sealed design that has been proven in the field with our shifter and turn signal product lines. Non-contact electronic switching technology that is used in this electronic shifter provides outstanding reliability and elimination of contact wear that greatly enhances the life of this mechanism. The shifter is well suited to interface directly with electronic transmission control units providing application flexibility.



Specifications:

Outputs: 200 mA maximum
2,000,000 cycles

Operating Temperature: -40°C to +85°C

Operating Voltage Range: 3V to 12V

Applications:

- On-Highway Trucks
- Off-Highway
- Material Handling
- Construction
- Agriculture

Proportional Retarders

Features/Benefits:

- Reverse Voltage Protection
- Short Circuit Protection
- Over Voltage Protection
- Sealed Housing
- Rugged Positive-Locking Connector

Specifications:

- *Travel:* 25° maximum angle travel
- *Supply Voltage:* 9 VDC to 32 VDC
(12 VDC to 24 VDC Operating System)
- *Base Frequency:* 500 Hz
(±10% over temperature and input voltage)
- *Duty Cycle:* 10% to 90%
(±5% at limits of travel)
- *Output Voltage:* Pulse-width-modulated
(0-7V amplitude)
- *Wiring & Connection:* Receptacle compatible with positive-locking Deutsch DT06-6S connector with 18 AWG (minimum wiring to conform to 1E815)

Applications:

- Off-Highway Trucks
- Agriculture
- Construction

The Hobbs Proportional Retarder is a shift-lever handle that attaches to the steering column of a vehicle and gives an electronic pulse-width-

modulated output signal that is proportional to the position of the lever. In standard



mounting position, output signal has 10% duty cycle when lever is pulled towards operator to maximum extent. When moved away from operator to its maximum travel, the lever snaps into a detent indicating the output signal now has 90% duty cycle. The duty cycle between these two positions is a continuously variable function of position.

Hobbs Corporation

P.O. Box 19424

Springfield, Illinois 62794-9424

Phone: (217) 753-7752

Fax: (217) 753-7789

email: hobbs.marketing@hobbs-corp.com

www.hobbs-corp.com

© J.W. HOBBS CORPORATION

30-1100

